

UB2 Connector

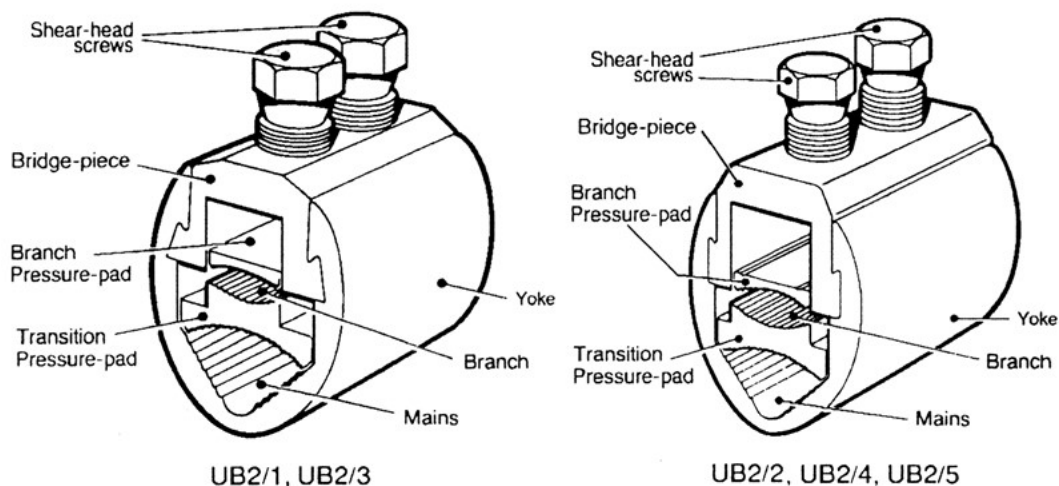

Principle Application

Stranded service connections from standard sector shaped mains conductors in the following ranges: -

Range

Connector reference	Core c.s.a. (mm ²)				Approx Unit Wt. (gms)
	Mains		Branch		
	min.	max.	min.	max.	
UB2/1*	240	300	16	50	142
UB2/2*	240	300	50	95	230
UB2/3	400	500	50	95	240
UB2/4	400	500	150	185	345
UB2/5	150	185	16	50	126

*NOTE: UB2/1N & UB2/2N available for circular neutral conductor

The Sicame UB range of connectors has been designed specifically for use with polymeric heat shrink insulation materials. When fully assembled the connector forms a smooth, contoured profile, free from projections and sharp edges, allowing the insulation to shrink evenly around the connection. The connector is simple to fit and the Sicame shear head screw system ensures that the correct clamping pressure is applied. A consistent connection is achieved without the use of specialised tooling.

The connector is supplied individually packed complete with fitting instructions details of which are included with the technical data overleaf. Brass gauze can be supplied on request for use with copper conductors.

UB2 Connector

Physical Dimensions

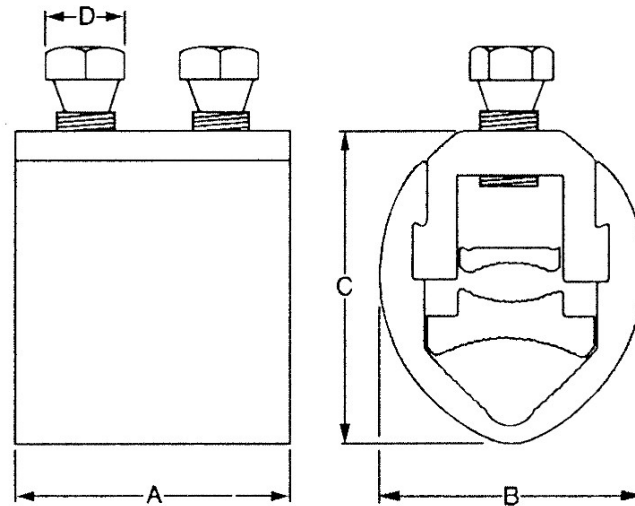

Ref. Code	Dimensions (mm)			
	A	B	C	D
UB2/1	40.0	45.2	48	13.0*
UB2/2	50.0	47.5	58.0	17.0
UB2/3	50.0	53.5	60.0	17.0
UB2/4	60.0	56.3	69.0	17.0
UB2/5	40.0	38.6	47.0	13.0*

* Denotes one screw only (centrally located)

Material

Aluminium Alloy

Fitting Instructions

Separate the main cable cores to enable the yoke of the connector to be fitted around the conductor. Strip a length of insulation equal to the length of the connector plus 5 mm from the core at the selected connection position. Set the branch core and cut to the required length. Strip the insulation as above. Thoroughly abrade all exposed conductors. Pass the connector yoke around the mains conductor and insert the transition pressure pad. Locate the branch core in the yoke and insert the pressure pad and bridge piece. Ensure assembly is correctly aligned and hold firmly. Complete the operation by tightening the screws a quarter of a turn at a time until both heads shear off.

If copper conductors are to be jointed they should be wrapped in brass gauze before insertion into the yoke to improve electrical stability of the aluminium/copper interface in the connection.