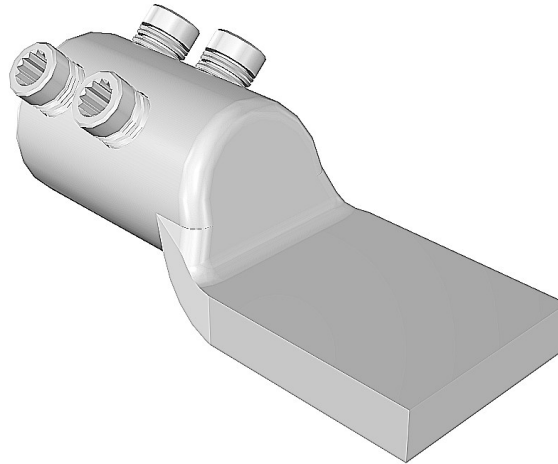

ML7 Connector**Principle Application:**

Termination of solid/stranded, aluminium/copper circular conductor cores.

Range:

Connector Reference (Part Number)	Core c.s.a. (mm ²)		Stud Size (mm)
	Min	Max	
ML7 (51904-99)	480	740	-
ML7-4 x 8 (51801-50)			4 x M8
ML7-4 x 10 (51801-70)			4 x M10
ML7-20			M20

Note: For jointing other core configurations/sizes please contact Sicame Engineering Dept

The **Sicame ML7** mechanical lugs are manufactured from an aluminium forging, thereby providing an integral moisture block. The lugs utilise the patented 'universal' range taking shear bolts.

The appropriate tooling is to be used at all times, typical examples shown below.

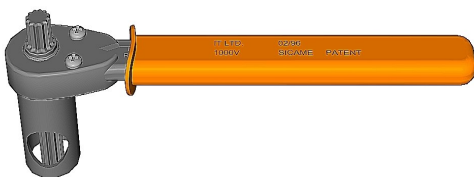

'JTS/7I' Universal Screw Ratchet Tool
(Insulated)



'JTS/16' Universal Screw Socket
(17mm A/F)

ML7 Connector

Physical Dimensions

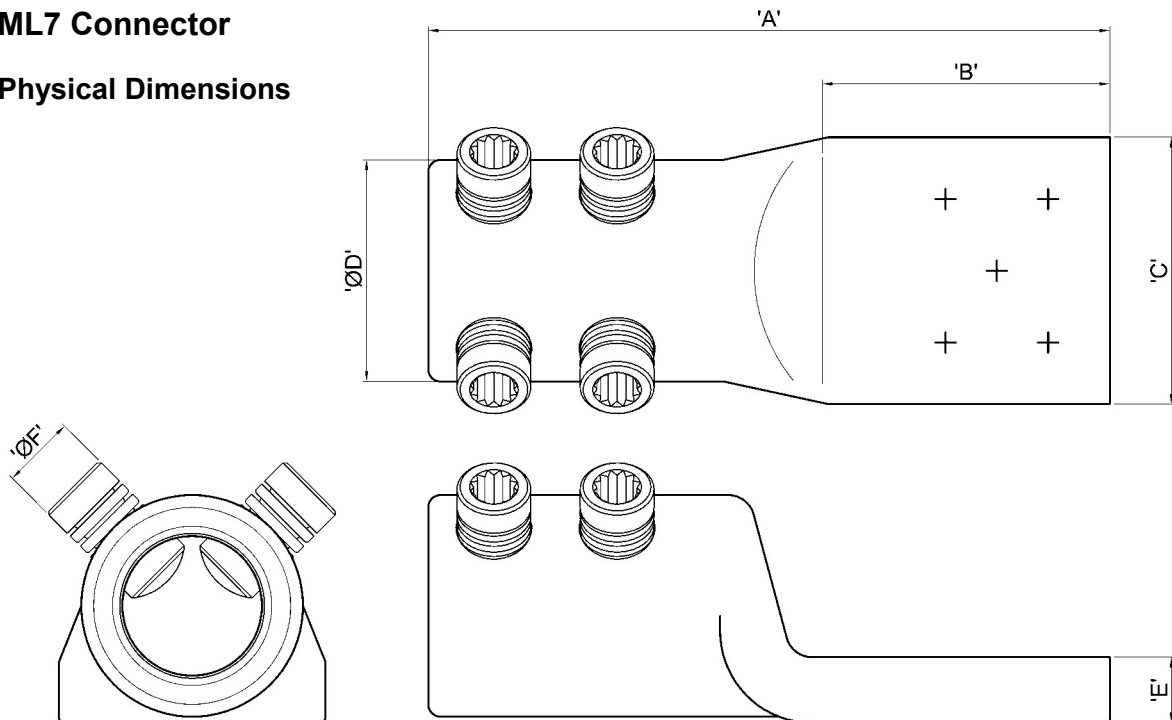

Connector Reference (Part Number)	Dimensions (mm)						Stud Size (mm)
	'A'	'B'	'C'	'ØD'	'E'	'ØF'	
ML7 (51904-00)	166	70	65	54	16	M18	-
ML7-4 x 8 (51801-50)	166	70	65	54	16	M18	4 x M8
ML7-4 x 10 (51801-70)	151	55	65	54	16	M18	4 x M10
ML7-20	166	70	65	54	16	M18	M20

Material:

Aluminium Alloy

Fitting Instructions:

1. Strip insulation from each core equal to the depth of the bore guide + 5mm.
2. Thoroughly abrade exposed conductors. (See note)
3. Fully insert core within the barrel of the connector.
4. Tighten the universal bolts consecutively one turn at a time until all the heads have sheared.

Note:

When jointing copper conductor wrap the supplied brass gauze around the core prior to installation.