

Mains branch mechanical split connector with moisture / contaminant block for Medium Voltage applications

MECHANICAL CONNECTORS

MB20 Connectors

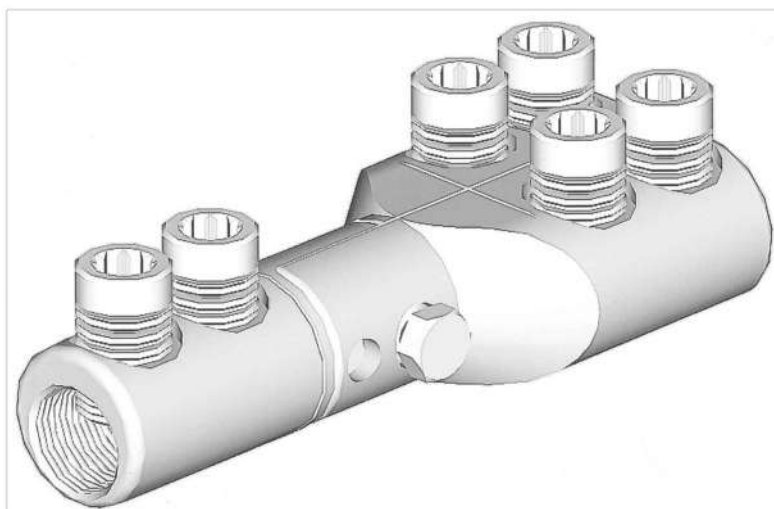

Principle Application

Mains branch jointing of stranded/solid sectoral conductors.

Range

PRODUCT REFERENCE	STRANDED CORE C.S.A. (mm ²)				SOLID CORE C.S.A. (mm ²)				APPROX UNIT WEIGHT (grams)
	MAIN		BRANCH/TAP		MAIN		BRANCH/TAP		
	MIN	MAX	MIN	MAX	MIN	MAX	MIN	MAX	
MB20/1	10	95	10	95	10	70	10	70	TBC
MB20/2	16	185	16	185	16	150	16	150	TBC
MB20/3	70	300	70	300	70	240	70	240	TBC
MB20/5	16	185	16	185	16	150	16	150	TBC

Secondary Application

Mains branch jointing of stranded/solid circular conductors.

Range

PRODUCT REFERENCE	STRANDED CORE C.S.A. (mm ²)				SOLID CORE C.S.A. (mm ²)				APPROX UNIT WEIGHT (grams)
	MAIN		BRANCH/TAP		MAIN		BRANCH/TAP		
	MIN	MAX	MIN	MAX	MIN	MAX	MIN	MAX	
MB20/1	10	95	10	95	10	185	10	185	TBC
MB20/2	16	185	16	185	16	300	16	300	TBC
MB20/3	70	300	70	300	70	400	70	400	TBC
MB20/5	16	185	16	185	16	300	16	300	TBC

Note: For jointing other core configurations/sizes please contact Sicame Engineering Dept

The **Sicame MB20** range of mechanical connectors incorporate an integral moisture/contaminant block and the split feature enables cable connection without "springing" the cores. The connector utilises the patented 'universal' range taking shear bolts.

Suitable for all cable voltages up to and including 11KV.

Mains branch mechanical split connector with moisture / contaminant block for Medium Voltage applications

MECHANICAL CONNECTORS

MB20 Connectors

Physical Dimensions

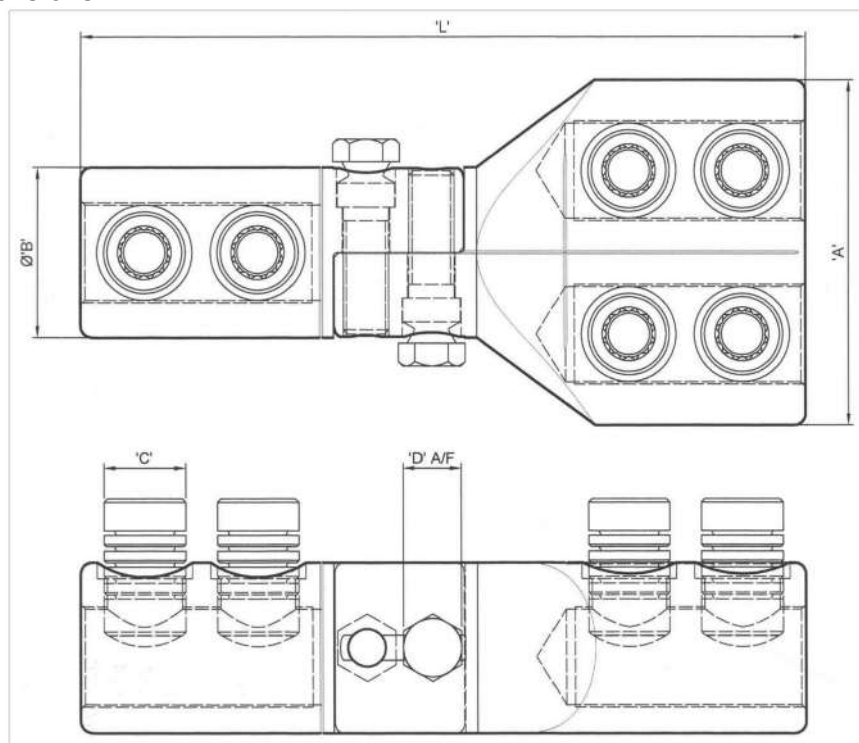

PRODUCT REFERENCE	DIMENSIONS (mm)				
	L	A	B	C	D
MB20/1	145.5	55.0	28.0	M16	13mm A/F
MB20/2	148.5	62.0	32.0	M18	13mm A/F
MB20/3	166.5	76.0	37.5	M18	13mm A/F
MB20/5	160.0	76.0	37.5	M18	13mm A/F

Material: Aluminium Alloy

Fitting instructions

1. Strip insulation from each core equal to the depth of the bore guide +5mm.
2. Thoroughly abrade exposed conductor cores.
3. Separate the connector and place each half onto the conductor cores.
4. Bring both connector halves together and align. Screw the two central joining screws into the connector and tighten consecutively one turn at a time until both screws have sheared.
5. Tighten the universal shear bolts consecutively one turn at a time until the bolts have sheared.
6. Deburr and clean the connector as appropriate **ensuring the profile of the screws are level with the connector body and leaving no sharp edges.**

Note: When jointing copper conductors, wrap the core with the brass gauze supplied prior to installation.

Important: Please note that when using MF/MB connectors in joints nominally rated in excess of 3.3kV, it is essential that the jointing system suppliers instructions for stress relieving and re-insulation techniques are strictly adhered to.

©COPYRIGHT

Sicame UK Ltd operates a continuous product design development and improvement programme and offers active co-operation establishing satisfactory procedures and systems to meet new or unusual jointing situations. The company reserves the right to introduce modifications to the above designs and specifications without prior notice.

sicame
UK

2.20

SEPTEMBER 2023